

- Phoenix units can be used with prefinished or unfinished wallboard
- Shipped with steel components pre-installed for convenient installation, including all installation hardware
- Design continuity in color and profile configurations can be maintained without job site finishing
- Phoenix is factory finished and design coordinated with AVALON's non-rated 20/ 45 minute Eagle series
- No sill starter/ blocking needed
- 4-1/2" x 4-1/2" Hinges
- ANSI Strike
- No Extended Lip Strike Required
- 1" Wide Door Stop
- No Additional Bracket needed for Parallel Arm Closer
- Heavy-duty All Aluminum Hinge Backer
- Mitre Corners Available
- Double-Egress Frame



Clear Anodized



Standard Black



Standard White



Standard Bronze



Standard Grey



Champagne

PREMIUM HARDWARE

- Heavy Weight Hinge preps
- Electric Hinge preps
- 5" x 5" Hinge preps
- Concealed Closers
- EPT – Concealed & Hinge types
- Electric Strikes - All types
- SOSS Hinges - Concealed Hinges
- Concealed Overhead Stops
- Flush Bolts
- Backers Included & Installed

90 Minute Aluminum Door Frame

PHOENIX was the first aluminum door frame to meet or exceed the criteria specified in ASTM E-152, UL 10B, NFPA 252, CSFM 43.7, UBC 43.2 & CAN4 S-104 for 90 minute fire-rated assemblies.



No Field Notching of Trim Required

Rough Opening for 1-1/2" or 2" profile:

Opening Size + 3/4" each side

Example: 3070 Frame

$3/4" + 36" \text{ width} + 3/4" = 36-1/2" \text{ rough opening}$

Available Throat Sizes:

2-1/4" to 16-1/2" in 1/8" increments - 1-1/2" & 2" Face



AVALON
INTERNATIONAL
ALUMINUM

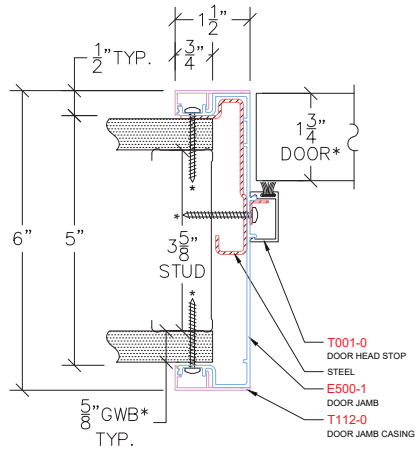

P100 - DOOR JAMB

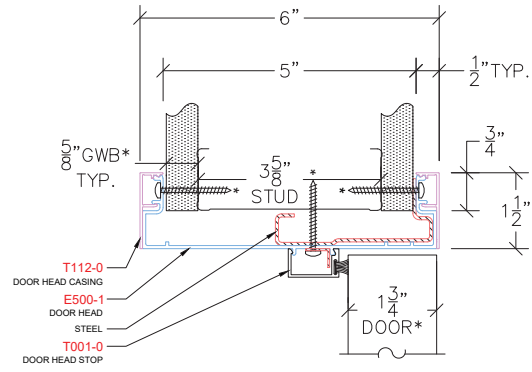

P200 - DOOR HEAD

